

SOT-89-3L Plastic-Encapsulate MOSFETS

2N7002X MOSFET(N-Channel)

$V_{(BR)DSS}$	$R_{DS(on)MAX}$	I_D
60V	5Ω@10V	115mA
	7Ω@5V	

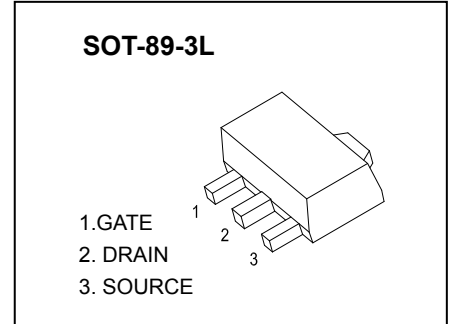

FEATURES

- High density cell design for low $R_{DS(on)}$
- Voltage controlled small signal switch
- Rugged and reliable
- High saturation current capability

APPLICATION

- Load Switch for Portable Devices
- DC/DC Converter

MARKING

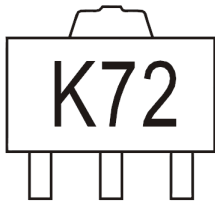

Equivalent Circuit

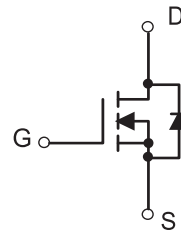

MAXIMUM RATINGS ($T_a=25^{\circ}C$ unless otherwise noted)

Symbol	Parameter	Value	Unit
V_{DS}	Drain-Source Voltage	60	V
V_{GS}	Gate-Source Voltage	±20	V
I_D	Drain Current	115	mA
P_D	Power Dissipation	500	mW
T_J	Junction Temperature	150	°C
T_{STG}	Storage Temperature	-55~+150	°C
$R_{\theta JA}$	Thermal Resistance from Junction to Ambient	250	°C/W

MOSFET ELECTRICAL CHARACTERISTICS

$T_a=25\text{ }^\circ\text{C}$ unless otherwise specified

Parameter	Symbol	Test conditions	Min	Typ	Max	Unit
Drain-source breakdown voltage	$V_{(BR)DSS}$	$V_{GS}=0V, I_D=250\mu A$	60			V
Gate-threshold voltage*	$V_{(GS)th}$	$V_{DS}=V_{GS}, I_D=250\mu A$	1		2.5	
Gate-body leakage	I_{GSS}	$V_{DS}=0V, V_{GS}=\pm 20V$			± 80	nA
Zero gate voltage drain current	I_{DSS}	$V_{DS}=60V, V_{GS}=0V$			80	nA
Drain-source on-resistance*	$R_{DS(on)}$	$V_{GS}=10V, I_D=500mA$			5	Ω
		$V_{GS}=5V, I_D=50mA$			7	
Forward tranconductance*	g_{fs}	$V_{DS}=10V, I_D=200mA$	80			ms
Drain-source on-voltage	$V_{DS(on)}$	$V_{GS}=10V, I_D=500mA$			3.75	V
		$V_{GS}=5V, I_D=50mA$			0.375	V
Diode forward voltage*	V_{SD}	$I_S=115mA, V_{GS}=0V$	0.55		1.2	V
Turn-on time**	$t_{d(on)}$	$V_{DD}=25V, R_L=50\Omega, I_D=500mA,$ $V_{GEN}=10V, R_G=25\Omega$			20	ns
Turn-off time**	$t_{d(off)}$				40	
Input capacitance**	C_{iss}	$V_{DS}=25V, V_{GS}=0V, f=1MHz$			50	pF
Output capacitance**	C_{oss}				25	
Reverse transfer capacitance**	C_{rss}				5	

* Pulse Test: Pulse width $\leq 300\mu s$, duty cycle $\leq 2\%$.

** These parameters have no way to verify.

Typical Characteristics

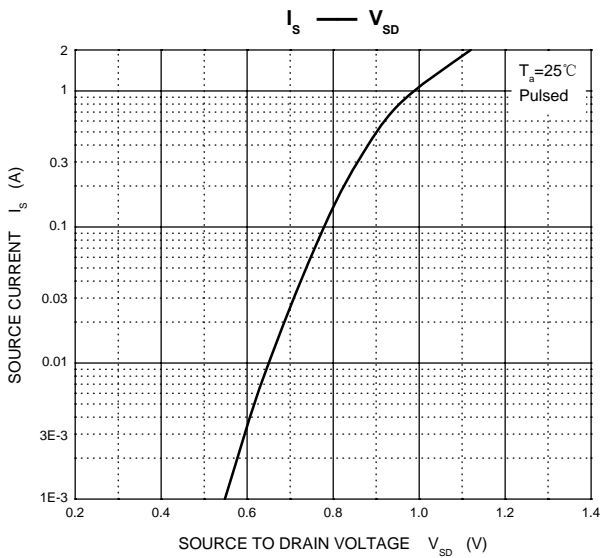
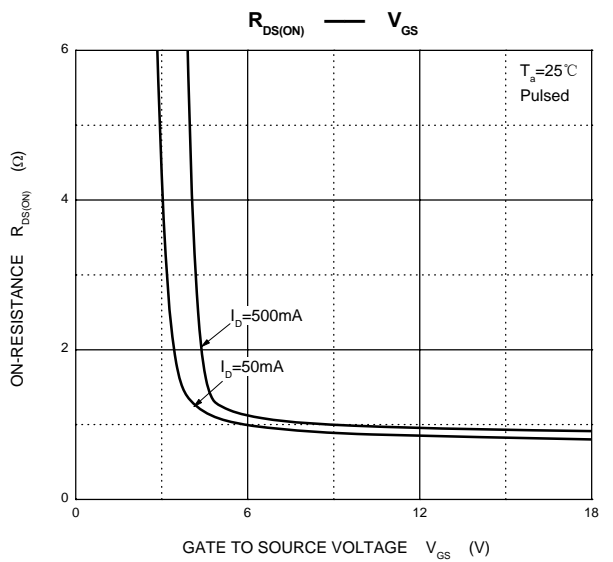
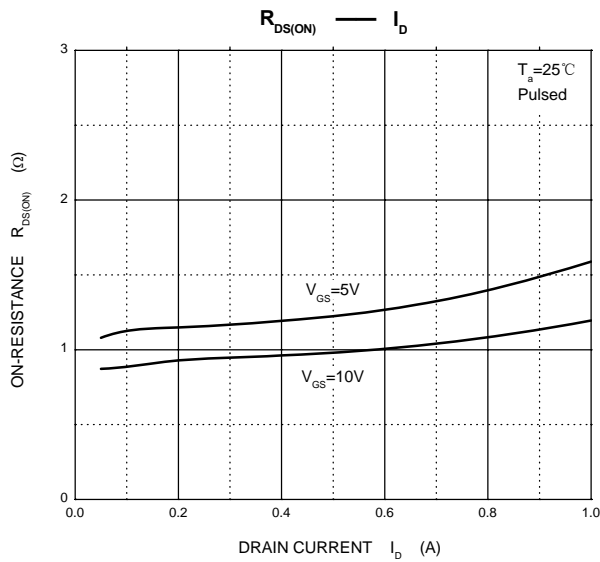
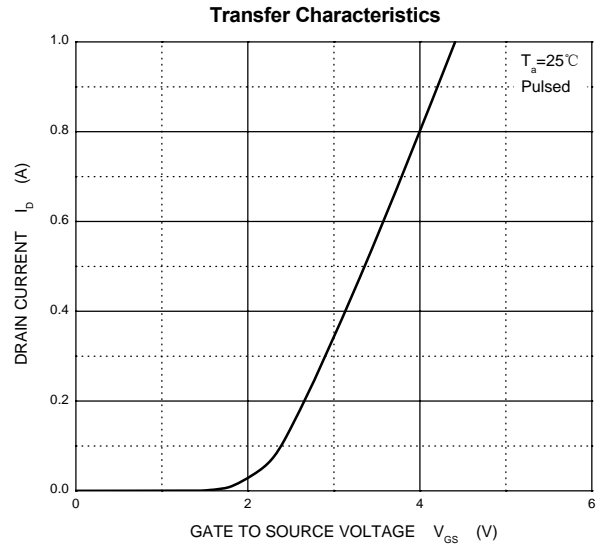
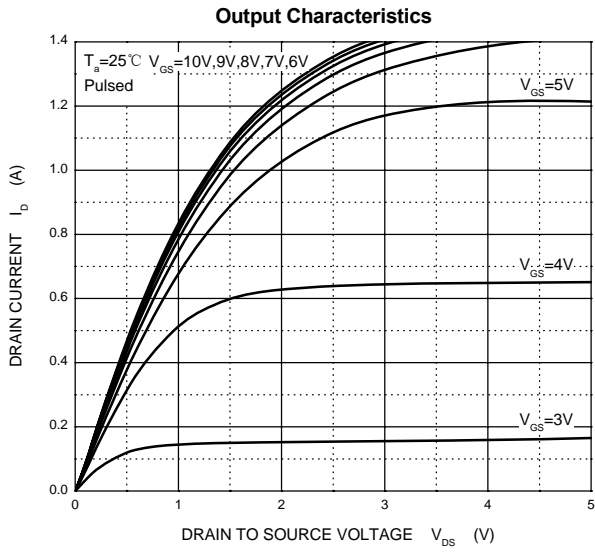

SOT-89-3L Package Outline Dimensions

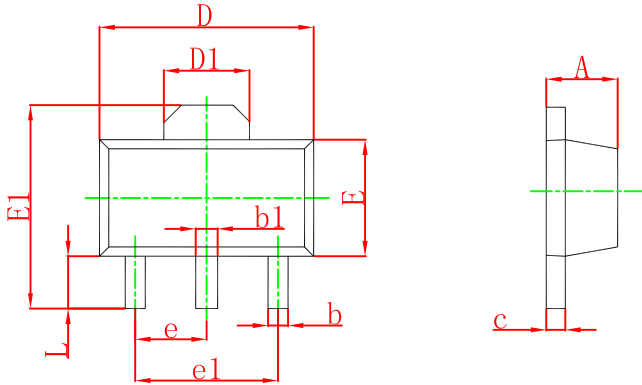

Symbol	Dimensions In Millimeters		Dimensions In Inches	
	Min	Max	Min	Max
A	1.400	1.600	0.055	0.063
b	0.320	0.520	0.013	0.020
b1	0.400	0.580	0.016	0.023
c	0.350	0.440	0.014	0.017
D	4.400	4.600	0.173	0.181
D1	1.550 REF.		0.061 REF.	
E	2.300	2.600	0.091	0.102
E1	3.940	4.250	0.155	0.167
e	1.500 TYP.		0.060 TYP.	
e1	3.000 TYP.		0.118 TYP.	
L	0.900	1.200	0.035	0.047

SOT-89-3L Suggested Pad Layout

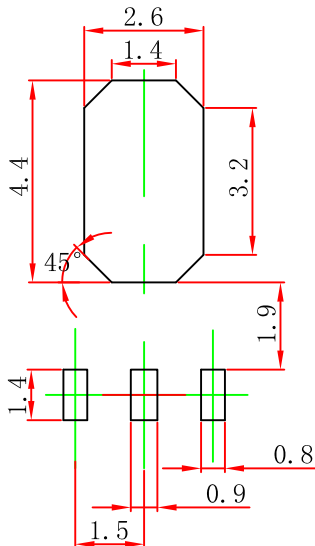

Note:

1. Controlling dimension: in millimeters.
2. General tolerance: ± 0.05 mm.
3. The pad layout is for reference purposes only.

NOTICE

SE reserve the right to make modifications, enhancements, improvements, corrections or other changes without further notice to any product herein. SE does not assume any liability arising out of the application or use of any product described herein.

SOT-89-3L Tape and Reel

SOT-89-3L Embossed Carrier Tape

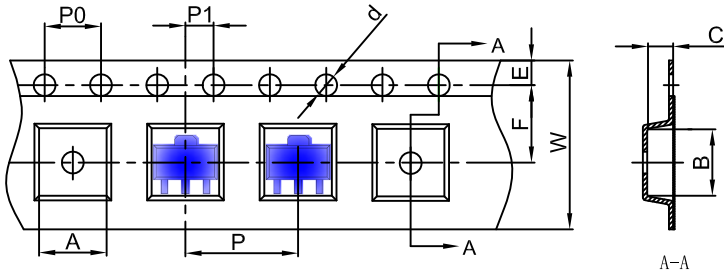

Packaging Description:

SOT-89-3L parts are shipped in tape. The carrier tape is made from a dissipative (carbon filled) polycarbonate resin. The cover tape is a multilayer film (Heat Activated Adhesive in nature) primarily composed of polyester film, adhesive layer, sealant, and anti-static sprayed agent. These reeled parts in standard option are shipped with 1,000 units per 7" or 18.0 cm diameter reel. The reels are clear in color and is made of polystyrene plastic (anti-static coated).

Dimensions are in millimeter										
Pkg type	A	B	C	d	E	F	P0	P	P1	W
SOT-89-3L	4.85	4.45	1.85	Ø1.50	1.75	5.50	4.00	8.00	2.00	12.00

SOT-89-3L Tape Leader and Trailer

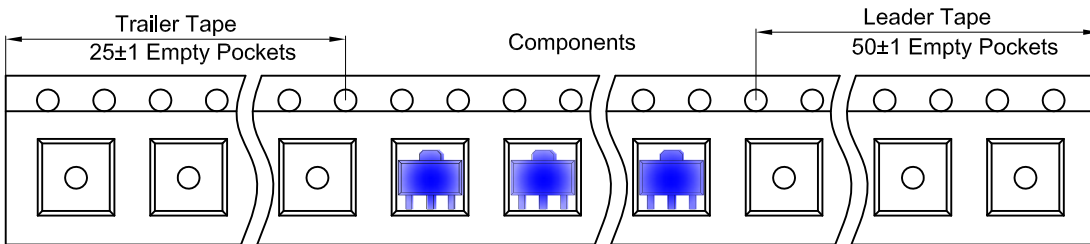

SOT-89-3L Reel

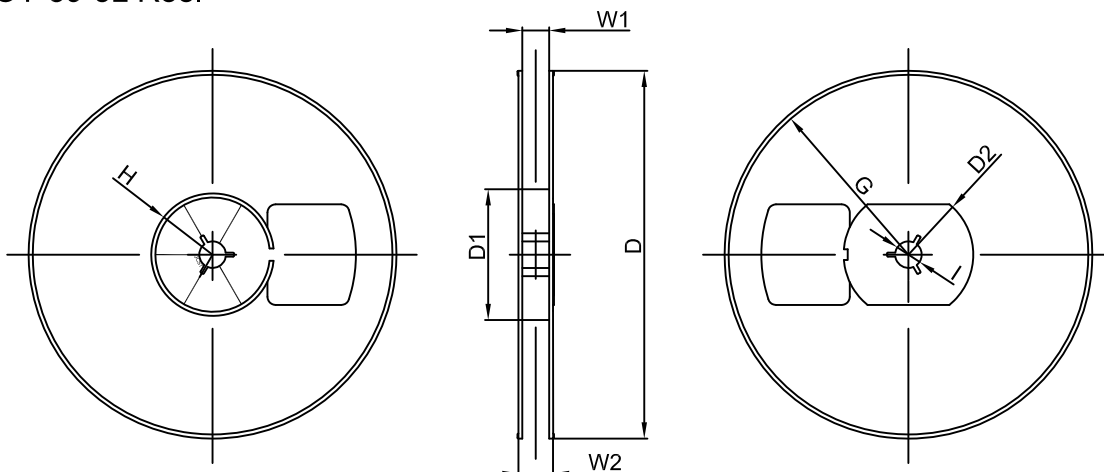

Dimensions are in millimeter								
Reel Option	D	D1	D2	G	H	I	W1	W2
7" Dia	Ø180.00	60.00	R32.00	R86.50	R30.00	Ø13.00	13.20	16.50

REEL	Reel Size	Box	Box Size(mm)	Carton	Carton Size(mm)	G.W.(kg)
1000 pcs	7 inch	10,000 pcs	203×203×195	40,000 pcs	438×438×220	