

## ESD Protection Devices

Sinbles' ESD line of devices help protect I/O ports on HDMI 1.3, portable video players, LCD & plasma TVs, USB 2.0, digital visual interface (DVI), and antenna switches. ESD devices shunt electrostatic discharge away from sensitive circuitry in HDTV equipment, printers, laptops, cellular phones, and other portable devices.

ESD devices offer many advantages over traditional protection devices, such as multi layer varistors (MLVs), which may degrade or distort the signal in high data rate circuits. Compared to transient voltage suppression (TVS) diodes and miniature gas discharge tubes (GDTs), ESD devices provide a more compact form factor and an economical solution for the shrinking profiles of today's compact information appliances.

Available in a range of form factors, our ESD protection devices provide low capacitance, and meet transmission line pulse (TLP) testing, as well as IEC61000-4-2 testing.

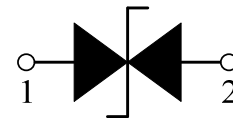

Equivalent Circuit

### Benefits

- ESD protection for high frequency applications (HDMI 1.3)
- Smaller form factor for board space savings
- Helps protect sensitive electronic circuits against damage caused by electrostatic discharge (ESD) events
- Assists equipment to pass IEC 61000-4-2, level 4 testing

### Features

- RoHS compliant
- Halogen free (refers to: Br $\leq$ 900ppm, Cl $\leq$ 900ppm, Br+Cl $\leq$ 1500ppm)
- 0.15 pF (typical) capacitance
- Low-leakage current
- Low-clamping voltage
- Fast response time (< 1ns)
- Capable of withstanding numerous ESD strikes
- Compatible with standard reflow installation procedures
- Thick film technology
- Bi-directional protection

### Applications

- HDMI 1.3 interfaces
- LCD & plasma TV
- Cellular phones
- Antennas
- Portable video players
- Portable devices (PDA, DSC, BlueTooth)
- Printer ports
- Satellite radios
- USB 2.0 and IEEE 1394 interfaces
- DVI
- GPS systems

**Surface Mount Polymeric ESD Suppressor**

**Electrical Characteristics (T<sub>A</sub> =25°C)**

Parameter	Symbol	Test Conditions	Min.	Typ.	Max.	Units
Continuous Operating Voltage	V <sub>DC</sub>	---	---	---	5	V
Trigger Voltage	V <sub>T</sub>	IEC61000-4-2 8KV contact discharge	---	300	---	V
Clamping Voltage	V <sub>C</sub>	IEC61000-4-2 8KV contact discharge	---	30	---	V
Leakage Current	I <sub>L</sub>	DC 5V shall be applied on component	---	---	10	nA
Capacitance	C <sub>P</sub>	Measured at 10MHz	---	0.15	---	pF
ESD Pulse Withstand	Pulses	IEC61000-4-2 8KV contact discharge	1000	---	---	---

Notes:

1. Trigger and clamping voltage are measured per IEC 61000-4-2, 8KV contact discharge method.
2. After reliability tests such as high Temp storage, Temp cycles, continuous ESD strike etc, the maximum leakage current is less than 1uA.

**Typical Device Capacitance VS. Frequency**

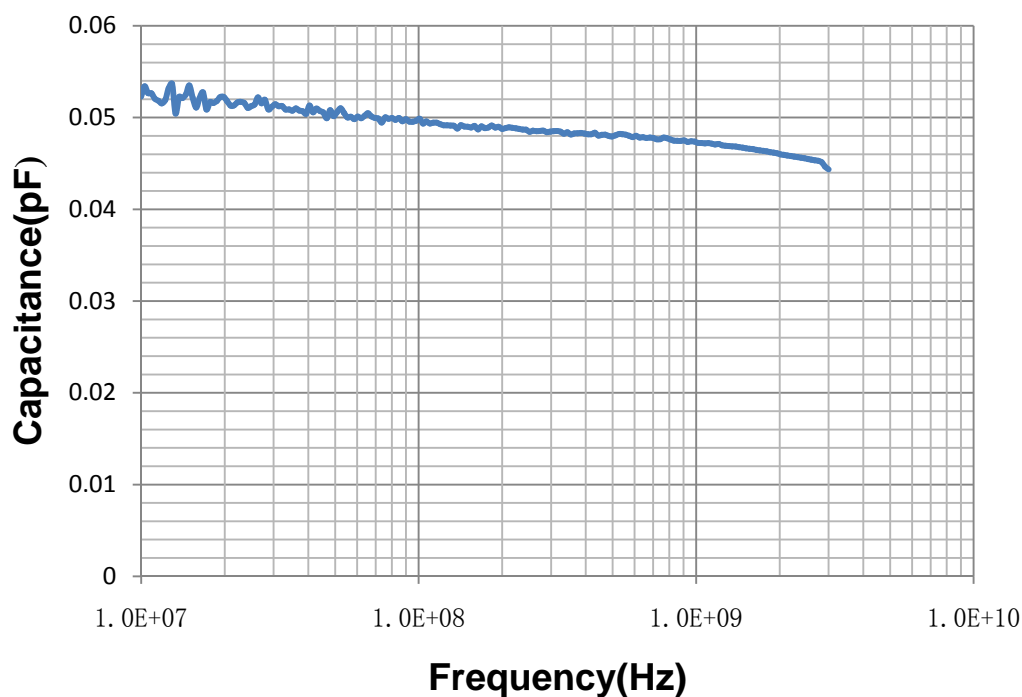

Surface Mount Polymeric ESD Suppressor

ESD Protection for HDMI

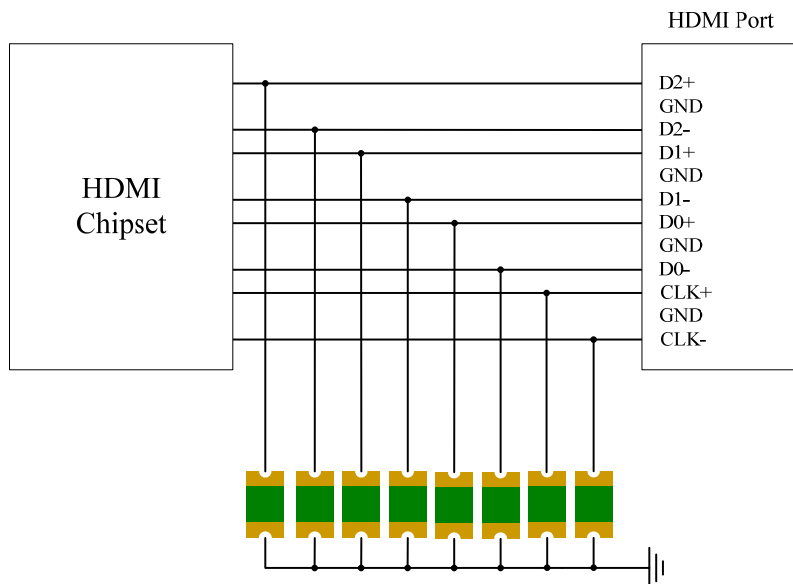

Package Dimension

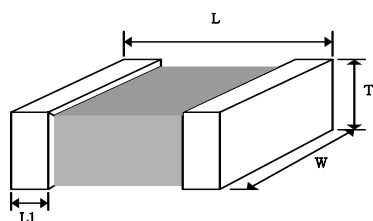

CODE	DIMENSION (mm)			
	L	W	T	L1
0402	1.0±0.05	0.5±0.05	0.5±0.05	0.2+ 0.15/-0.1

Surface Mount Polymeric ESD Suppressor

Taping Specification

1. Tape Dimension

Unit: Millimeters

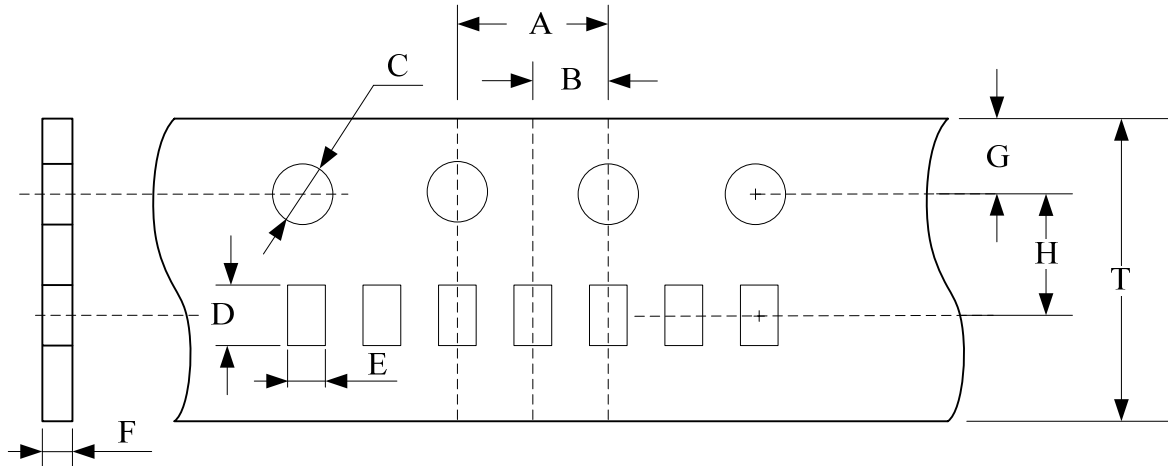

A	B	C	D	E	F	G	H	T
4.00±0.10	2.00±0.10	∅1.55±0.10	1.90±0.05	1.0±0.05	0.48±0.05	1.75±0.10	3.50±0.05	8.00±0.30

2. Reel Dimension

Unit: Millimeters

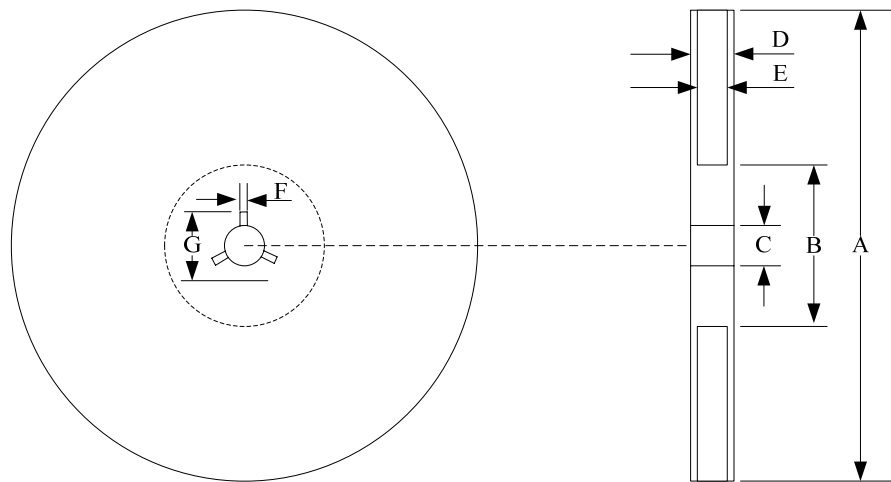

A	B min.	C	D	E	F	G
178.0 ±2.0	50.0	13.0±0.5	13.0±1.0	9.40±1.0	2.0 ±0.5	21.0±0.8

Surface Mount Polymeric ESD Suppressor

Soldering Parameters

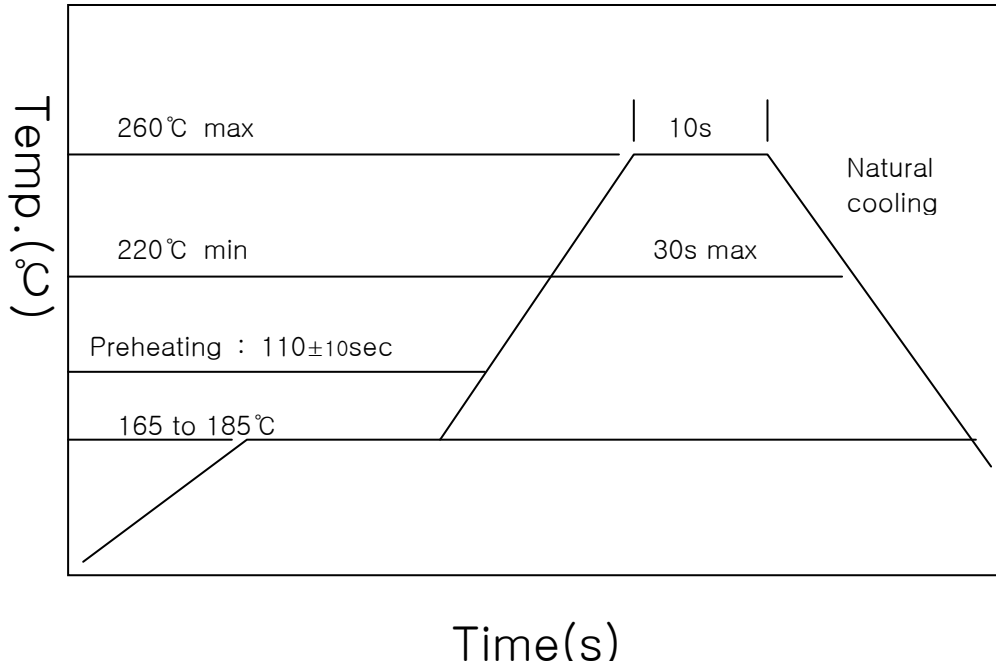

Land Pattern

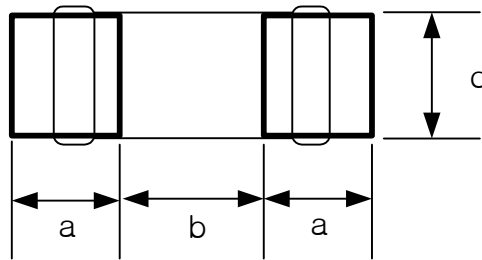

Size	a	b	c
0402	0.4~0.6	0.4~0.5	0.4~0.6