

ES2A ~ ES2J

2.0Amp Surface Mount Super Fast Rectifiers

Features

- The plastic package carries Underwriters Laboratory Flammability Classification 94V-0
- Super fast speed switching for high efficiency
- Glass passivated junction chip
- Low reverse leakage
- High forward surge current capability
- High temperature soldering guaranteed
250°C/10 seconds at terminals

Mechanical Data

Case: JEDEC DO-214AC molded plastic body
Terminals: Solder plated, solderable per MIL-STD-750, Method 2026
Polarity: Color band denotes cathode end
Mounting Position: Any
Weight : 0.002 ounce, 0.07 grams

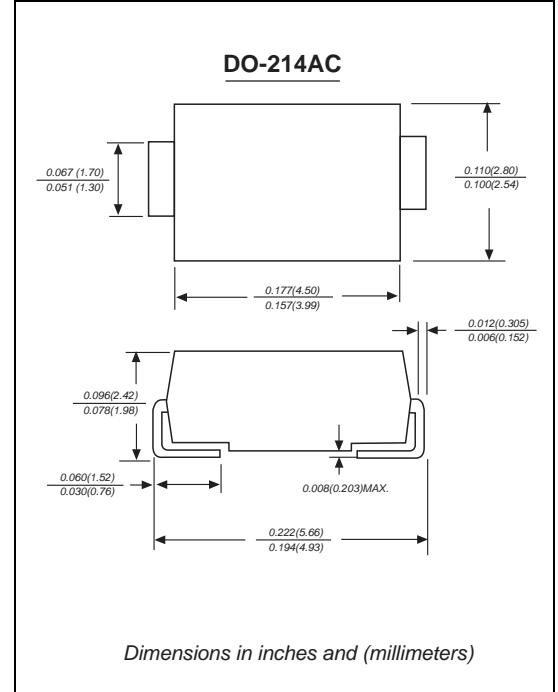

Maximum Ratings And Electrical Characteristics

Ratings at 25°C ambient temperature unless otherwise specified. Single phase half-wave 60Hz, resistive or inductive load, for capacitive load current derate by 20%.

	SYMBOLS	ES2A	ES2B	ES2C	ES2D	ES2E	ES2G	ES2J	UNITS
Maximum repetitive peak reverse voltage	V_{RRM}	50	100	150	200	300	400	600	VOLTS
Maximum RMS voltage	V_{RMS}	35	70	105	140	210	280	420	VOLTS
Maximum DC blocking voltage	V_{DC}	50	100	150	200	300	400	600	VOLTS
Maximum average forward rectified current at $T_L=55^\circ\text{C}$	$I_{(AV)}$	2.0							Amp
Peak forward surge current 8.3ms single half sine-wave superimposed on rated load (JEDEC Method)	I_{FSM}	50							Amps
Maximum instantaneous forward voltage at 2.0A	V_F	0.95				1.25		1.7	Volts
Maximum DC reverse current $T_A=25^\circ\text{C}$ at rated DC blocking voltage $T_A=100^\circ\text{C}$	I_R	5.0 50.0							μA
Maximum reverse recovery time (Note 1)	T_{rr}	35							ns
Typical junction capacitance (Note 2)	C_J	15							pF
Typical thermal resistance (Note 3)	R_{qJA}	60							$^\circ\text{C/W}$
Operating junction and storage temperature range	T_J, T_{STG}	-50 to +155							$^\circ\text{C}$

Note: 1.Reverse recovery time test condition: $I_F=0.5\text{A}$ $I_R=1.0\text{A}$ $I_{rr}=0.25\text{A}$
 2.Measured at 1MHz and applied reverse voltage of 4.0V D.C.
 3.P.C.B. mounted with 0.2x0.2 "(5.0x5.0mm) copper pad areas

Ratings And Characteristic Curves

ES2A THRU ES2J

FIG. 1- FORWARD CURRENT DERATING CURVE

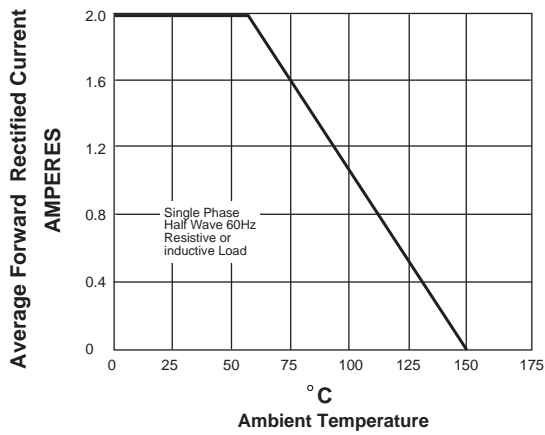

FIG. 2-MAXIMUM NON-REPETITIVE PEAK FORWARD SURGE CURRENT

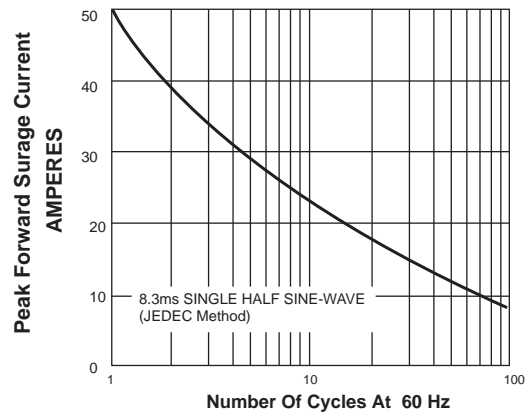

FIG. 3-TYPICAL INSTANTANEOUS FORWARD CHARACTERISTICS

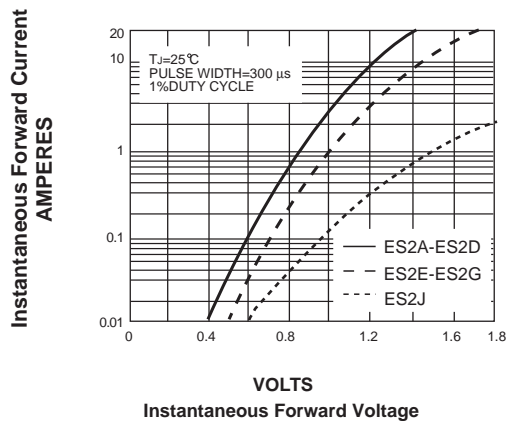

FIG. 4-TYPICAL REVERSE CHARACTERISTICS

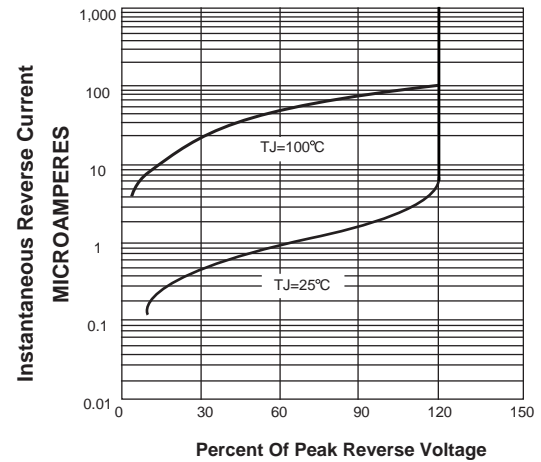

FIG. 5-TYPICAL JUNCTION CAPACITANCE

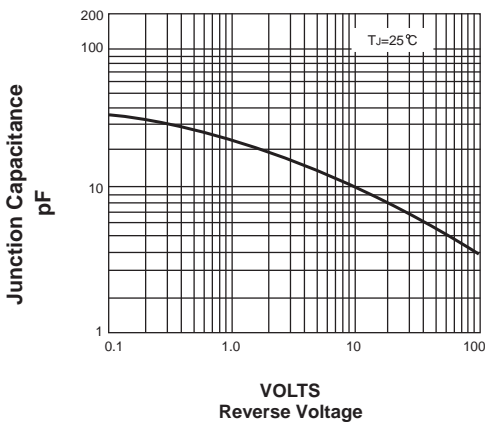

FIG. 6-TYPICAL TRANSIENT THERMAL IMPEDANCE

