

HER501 ~ HER508 5.0Amp High Efficiency Rectifiers

Features

- ◆ The plastic package carries Underwriters Laboratory Flammability Classification 94V-0
- ◆ High speed switching for high efficiency
- ◆ Open-Junction chip ,silastic passivated
- ◆ Low reverse leakage
- ◆ High forward surge current capability
- ◆ High temperature soldering guaranteed
250°C/10 seconds at terminals

Mechanical Data

Case: JEDEC DO-27 molded plastic body

Terminals: Solder plated, solderable per MIL-STD-750, Method 2026

Polarity: Color band denotes cathode end

Mounting Position: Any

Weight : 0.04 ounce, 1.10 grams

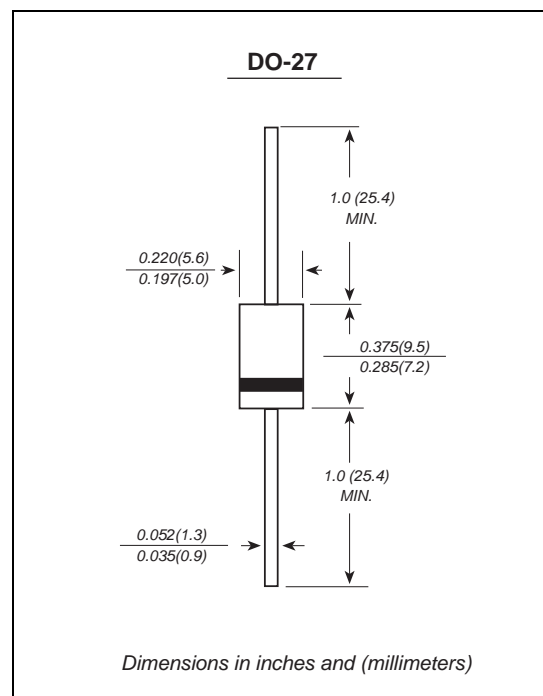

Maximum Ratings And Electrical Characteristics

Ratings at 25°C ambient temperature unless otherwise specified. Single phase half-wave 60Hz, resistive or inductive load, for capacitive load current derate by 20%.

	SYMBOLS	HER501	HER502	HER503	HER504	HER505	HER506	HER507	HER508	UNITS
Maximum repetitive peak reverse voltage	V_{RRM}	50	100	200	300	400	600	800	1000	VOLTS
Maximum RMS voltage	V_{RMS}	35	70	140	210	280	420	560	700	VOLTS
Maximum DC blocking voltage	V_{DC}	50	100	200	300	400	600	800	1000	VOLTS
Maximum average forward rectified current at $T_L=50^\circ\text{C}$	$I_{(AV)}$	5.0								Amp
Peak forward surge current 8.3ms single half sine-wave superimposed on rated load (JEDEC Method)	I_{FSM}	200								Amps
Maximum instantaneous forward voltage at 5.0A	V_F	1.0		1.3		1.7			Volts	
Maximum DC reverse current $T_A=25^\circ\text{C}$ at rated DC blocking voltage $T_A=100^\circ\text{C}$	I_R	10.0 200.0								μA
Maximum reverse recovery time (Note 1)	T_{rr}	50					75			ns
Typical junction capacitance (Note 2)	C_J	100					65			pF
Typical thermal resistance (Note 3)	R_{qJA}	10								$^\circ\text{C/W}$
Operating junction and storage temperature range	T_J, T_{STG}	-50 to +155								$^\circ\text{C}$

Note: 1.Reverse recovery time test condition: $I_F=0.5\text{A}$ $I_R=1.0\text{A}$ $I_{rr}=0.25\text{A}$

2.Measured at 1MHz and applied reverse voltage of 4.0V D.C.

3.Thermal resistance from junction to ambient at 0.375 "(9.5mm)lead length,P.C.B. mounted

Ratings And Characteristic Curves

HER501 THRU HER508

FIG. 1- FORWARD CURRENT DERATING CURVE

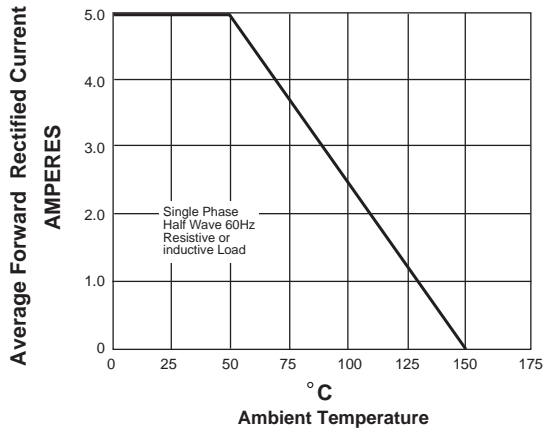

FIG. 2-MAXIMUM NON-REPETITIVE PEAK FORWARD SURGE CURRENT

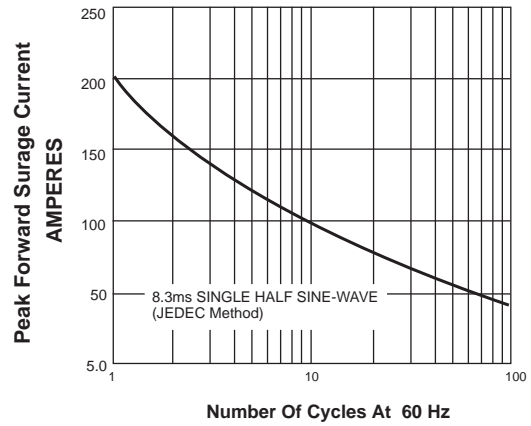

FIG. 3-TYPICAL INSTANTANEOUS FORWARD CHARACTERISTICS

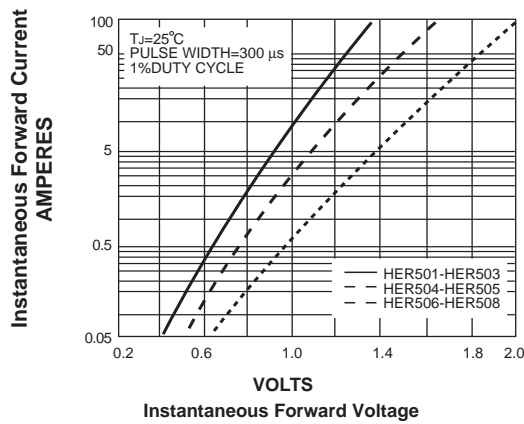

FIG. 4-TYPICAL REVERSE CHARACTERISTICS

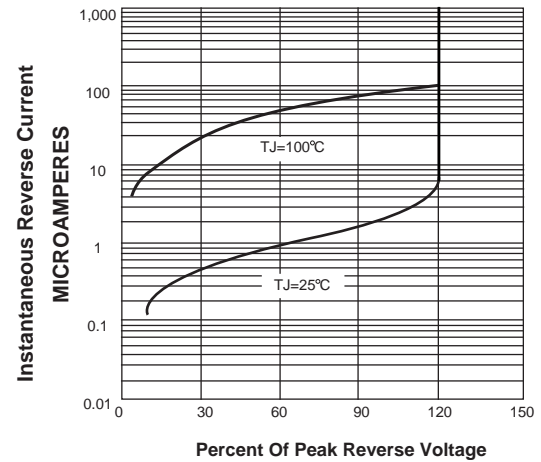

FIG. 5-TYPICAL JUNCTION CAPACITANCE

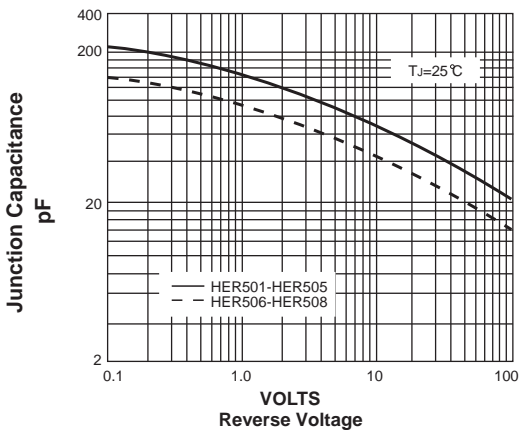

FIG. 6-TYPICAL TRANSIENT THERMAL IMPEDANCE

